

## PRODUCT INFORMATION

PROCESS ANALYSIS

UVAS PLUS SC

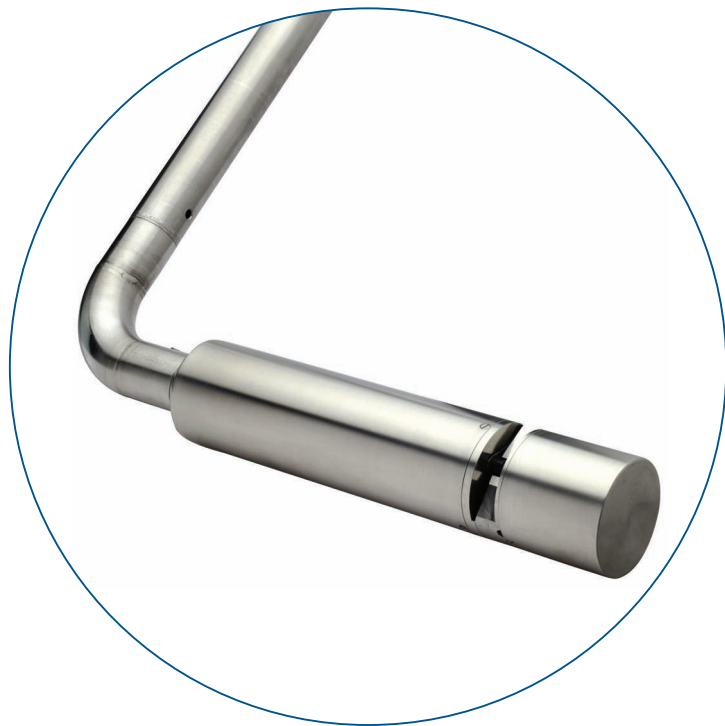

# Continuous measurement of organic load: UVAS plus sc

- **No sampling or sample conditioning**
- **Instant measured values**
- **No reagents**
- **Self-cleaning probe**

### **Reagent-free measurement of organic load**

The UVAS plus sc process probe measures the spectral absorption coefficient of a fluid at 254 nm. The SAC 254 is a measure of the organic content of the fluid. The probe is simply submerged in the fluid, without taking samples. No reagents have to be added and the measured values are immediately available.

### **Fast results, simple handling, low costs**

The UVAS plus sc probe is mounted in the fluid and supplies results within seconds. Handling and maintenance are very simple, thanks to automatic cleaning with a wiping system. The reagent-free measurement method yields reliable measured values for extremely low operating costs.



**LANGE** 

**Installed immersion probe**

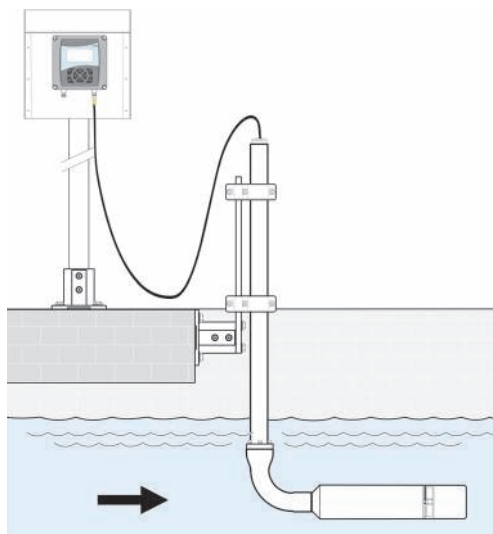

**UVAS plus sc in the flow-through unit**

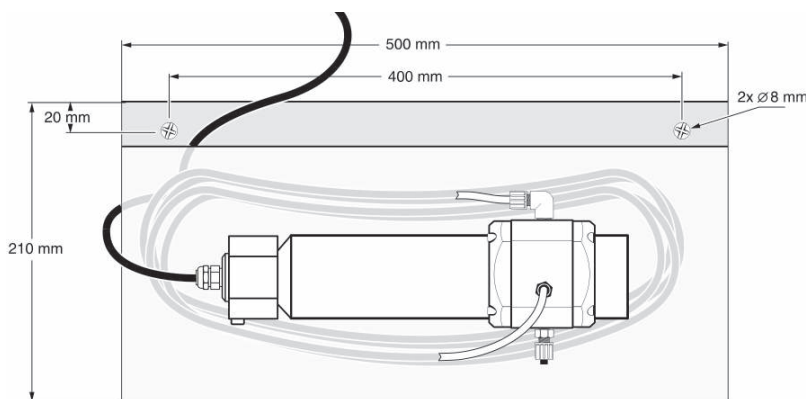

**Technical data**

<b>Measuring method</b>	UV absorption measurement (2-beam method), reagent-free
<b>Measurement method</b>	SAC 254 to DIN 38404 C3
<b>Measuring range</b>	0.01-60 m <sup>-1</sup> (50 mm), 0.1-600 m <sup>-1</sup> (5 mm), 0-500 m <sup>-1</sup> (2 mm), 2-3,000 m <sup>-1</sup> (1 mm), calibratable for the sum parameters COD and TOC
<b>Path length</b>	1, 2, 5 and 50 mm
<b>Compensation</b>	550 nm
<b>Measurement interval</b>	>1 min
<b>Cable length</b>	10 m
<b>Pressure resistance of probe</b>	Max. 0,5 bar
<b>Ambient temperature</b>	+2°C to +40°C
<b>Cleaning</b>	Automatic wiper cleaning
<b>Material</b>	Probe housing made of stainless steel 1.4571
<b>Weight</b>	Approx. 3.6 kg
<b>Inspection interval</b>	6 months
<b>Maintenance</b>	1 h/month, typical
<b>Sample flow</b>	At least 0.5 l/h sample in the flow-through unit
<b>Sample connector</b>	Flexible tube (ID 4 mm/ OD 6 mm) in the flow-through unit
<b>Dimensions of the flow-through unit</b>	210 mm x 500 mm x 170 mm (H x L x D)
<b>Dimensions</b>	Approx. 70 mm x 333 mm (Dia. x L)
<b>Display unit</b>	SC 100 controller (model LXV401) or SC 1000 controller (model LXV400 and LXV402)

**Ordering information**

DESCRIPTION	ART. NO.
UVAS plus sc	
- 1 mm	LXV418.99.10001
- 2 mm	LXV418.99.20001
- 5 mm	LXV418.99.50001
- 50 mm	LXV418.99.90001
<b>ACCESSORIES</b>	
Basin rim mounting	LZX414.00.10000
Flow-through unit 2 mm SC probes	LZX869
Flow-through unit 5 mm SC probes	LZX867
Flow-through unit 50 mm SC probes	LZX868
<b>SPARE PARTS</b>	
Wiper profiles	
- 1 mm (5/pkg)	LZX148
- 2 mm (5/pkg)	LZX012
- 5 mm (5/pkg)	LZX117
- 50 mm (10/pkg)	LZX119

**HACH LANGE Services**



Contact us to place an order, request information or receive technical support.



Support on-site by expert sales team.

**HACH LANGE LTD**  
 Unit 1, Chestnut Road  
 Western Industrial Estate  
 IRL-Dublin 12  
 Tel. +353(0)1 4602522  
 Fax +353(0)1 4509337  
 info@hach-lange.ie  
 www.hach-lange.ie



Phone: (01) 460 25 22

